

© Crown copyright 2018
 Do not scale from drawings. Verify all dimensions on site prior to construction. This drawing is to be read in conjunction with all relevant documents and drawings. Report all discrepancies to MoJ immediately.
 No unauthorised use, disclosure, storage or copying.

- LAM INFO DASI OF L**
- This symbol identifies a Residual Risk that is recorded on the Design Risk Register and is relevant to this drawing.
 This drawing must be read in conjunction with the following project CDM documents:
 661277-0000-PEV-GTX0011-XX-HS-C-002_Design Risk Assessment.
 - This symbol identifies a Derogation that is recorded on the Derogation Schedule and is relevant to this drawing.
 This drawing must be read in conjunction with the following project Derogation documents:
 N/A

The above symbols can only be read when this drawing is in colour print

KEY:
 INDICATIVE DEVELOPMENT BOUNDARY (27.9ha)
 INDICATIVE OWNERSHIP BOUNDARY

Rev	Date	Description
P03	2021.05.24	SITE LAYOUT AND RED BOUNDARY UPDATED.
P02	2021.02.18	SUITABILITY STATUS REVISION.
P01	2021.02.11	FIRST ISSUE FOR STAGE 2.

This document references the following linked files

File Reference	Status	Revision
N/A	N/A	N/A

Project Status
 RIBA Stage 2

Client **Project**
Ministry of Justice **New Prisons Programme**
 Ministry of Justice, 102 Petty France, London, SW1H 9AJ

Project Description / Site
 New Prisons Programme
 Gartree 2

Project Address
 Site Adjacent to HMP Gartree

Building Type
 Site Infrastructure

Drawing Title
 Swept Path Analysis - Articulated Heavy Goods Vehicles

Originator Logo 	Drawn By MHA Date 11.02.2021
	Checked By PCA Date 11.02.2021
	Approved By PCA Date 11.02.2021

Drawing Number 661277-0000-PEV-GTX0011-ZZ-DR-C-2601 **Delref** D0100

Sheet No. 01 of 01 **Scale** 1:1000 **Orig. Sheet Size** @ A1 **Rev.** P03

Data Security Classification OFFICIAL **Suitability** S3

HGV Side View:

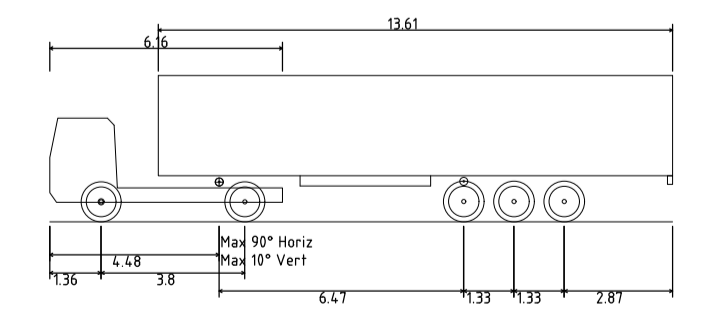

FTA Design Articulated Vehicle (1998)
 Overall Length 16.480m
 Overall Width 2.550m
 Overall Body Height 3.870m
 Min Body Ground Clearance 0.515m
 Max Track Width 2.470m
 Lock to lock Time 3.00s
 Kerb to Kerb Turning Radius 6.550m

HGV Plan View:



POTENTIAL BADGER SET RELOCATION