

Do not scale from drawings. Verify all dimensions on site prior to construction. This drawing is to be read in conjunction with all relevant documents and drawings. Report all discrepancies to MoJ immediately.

LAM INFO DASI OF L

POT SET

	This symbol identifies a Residual Risk that is recorded on the Design Risk Register and is relevant to this drawing.
	This symbol identifies a Derogation that is recorded on the Derogation Schedule and is relevant to this drawing.
	This drawing must be read in conjunction with the following project CDM documents: 661277-0000-PEV-GTX0011-XX-HS-C-002_Design Risk Assessment.
	N/A

The above symbols can only be read when this drawing is in colour print

KEY:

	INDICATIVE DEVELOPMENT BOUNDARY (27.9ha)
	INDICATIVE OWNERSHIP BOUNDARY

Rev	Date	Description
P04	2021.07.21	TUGS SHOWN ACCESSING HOUSEBLOCKS FROM MAIN ROAD INSTEAD FROM CASU YARD.
P03	2021.05.24	SITE LAYOUT AND RED BOUNDARY UPDATED.
P02	2021.02.18	SUITABILITY STATUS REVISION.
P01	2021.02.11	FIRST ISSUE FOR STAGE 2.

This document references the following linked files

File Reference	Status	Revision
N/A	N/A	N/A

Project Status  
RIBA Stage 2

Client Project **New Prisons Programme**

Ministry of Justice, 102 Petty France, London, SW1H 9AJ

Project Description / Site  
New Prisons Programme  
Gartree 2

Project Address  
Site Adjacent to HMP Gartree

Building Type  
Site Infrastructure

Drawing Title  
Swept Path Analysis-Electric Tug

Originator Logo <b>PICK EVERARD</b>	Drawn By MHA Date 11.02.2021
	Checked By PCA Date 11.02.2021
	Approved By PCA Date 11.02.2021

Drawing Number 661277-0000-PEV-GTX0011-ZZ-DR-C-2606 Delref D0100

Sheet No. 01 of 01 Scale 1:1000 Orig. Sheet Size @ A1 Rev. P04

Data Security Classification OFFICIAL Suitability S3

Electric Tug Side View:

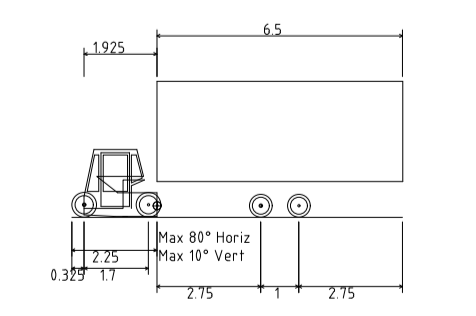

Electric Tug Plan View:

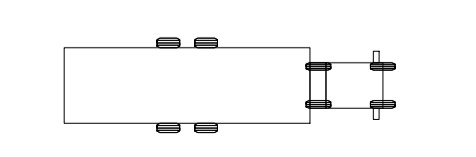

8.750m  
2.000m  
3.600m  
0.027m  
2.500m  
4.00s  
45.00°

POTENTIAL BADGER SET RELOCATION